

# THE MINISTRY OF INVESTMENT, TRADE AND INDUSTRY



**PROCUREMENT REFERENCE NUMBER:**

**BOBS/TRF/15/2020**

**REQUEST FOR QUOTATION FOR**

**SUPPLY, DELIVERY AND INSTALLATION OF FUEL  
DISPENSING EQUIPMENT FOR THE BOTSWANA BUREAU  
OF STANDARDS**

**DATE: 07<sup>th</sup> December 2020**

## REQUEST FOR QUOTATIONS (RFQ)

Reference Number: BOBS/TRF/15/2020

Contract Title: Purchase of Fuel Dispensing Equipment

Number of Lots: 3 (three)

1. Ministry of Investment, Trade and Industry is inviting you to submit a quote for the supply, delivery and installation of the following Fuel Dispensing Equipment for the **Botswana Bureau of Standards**, to be procured under Contract: **BOBS/TRF/12/2020**

Lot Number	Description	Quantities
1	200L Measuring Can (Prover Tank)	1
2	500L Measuring Can (Prover Tank)	1
3	Master Meter BM 950 + Wheel Trailer	1

2. Your quotation, in the required format (See Annex 2 to this RFQ), should be addressed and submitted to:

**SADC-TRF PROCUREMENT OFFICER**  
**Ministry of Investment, Trade and Industry**  
**Private Bag 004**  
**Gaborone**  
**Botswana**

**Attention: H. C. Maripe**

3. The **deadline** for submission of your quotations, to the address above is **16 December 2020, 15:00hours local time**.
4. All quotations should be dropped in the **Tender Box at 3<sup>rd</sup> floor** and quotations by E-mail or fax will NOT be accepted.
5. Your quotation(s) should be submitted as per the following instructions, and in accordance with the Terms and Conditions of the Request For Quotation.
  - (i) **PRICES:** The prices should be quoted CIP (as per Inco terms 2010) in the local currency, including all duties attached to the sale of the goods (such as VAT, customs duties, etc.) and transport to the final destination (BOBS Head Office).
  - (ii) **EVALUATION AND AWARD OF REQUEST FOR QUOTATION:** Quotations determined to be administrative (see Paragraph 2, 3,4,5,6 and 7) and technical compliant to the requirements will be evaluated by comparison of their prices per lot (defined as above). The award will be made to the bidder offering an administrative and technically compliant quotation at the **reasonable total price** for each lot.

- (iii) **VALIDITY OF THE OFFER:** Your quotation should be valid for a period of 90 days from the date of deadline for submission of quotations indicated in Paragraph 3 above.
- (iv) **DOCUMENTS TO BE ATTACHED:** Current Tax Clearance Certificate, Trading Licence and Certificate of Incorporation.
- (v) Your quotation should be accompanied by adequate technical documentation or catalogue(s) or equivalent and other printed material or pertinent information for items quoted.

7. The goods are expected to be **delivered** at Botswana Bureau of Standards, plot no. 55745, Airport Road, (Block 8) - Gaborone within 14 days from the signature of the Purchase Order.

8. Additional request for information and clarifications can be made no later than 5 days prior to deadline indicated in the paragraph 3 above, from:

The procuring authority: **Ministry of Investment Trade and Industry**

The contract manager: **Botswana Bureau of Standards**

Contact person: **Hwanano C. Maripe or Mable Mpofo  
Alfred Kgotlaetsile or Amen Ntlhaile**

Telephone: **3645488 or 3645430**

Fax: **3903120**

E-mail: **hcmaripe@gmail.com or mabel.mpofo@gmail.com**

**kgotlaetsile@bobstandards.bw or ntlhaile@bobstandards.bw**

## **ANNEXES:**

**ANNEX 1: Technical Specifications**

**ANNEX 2: Quotation Form**

**ANNEX 3: Technical Compliance Form**

**Sincerely,**

---

**Name: Ms Hwanano C. Maripe**

**Title: SADC TRF Procurement Officer**

**Date: ..... 2020**

**ANNEX 1: TECHNICAL SPECIFICATIONS**

The Goods and Related Services shall comply with following Technical Specifications and Standards:

**LOT 1: 200L Measuring Can (Prover Tank)**

Specifications	Requested by BOBS
Quantity	1
Model	
Warranty	At least 2 years onsite
Colour	Any
New	Yes
Material: Stainless Steel 304 with 2 x Thermometer Wells Complete with Trailer and all accessories as in the drawing shown below.	200L

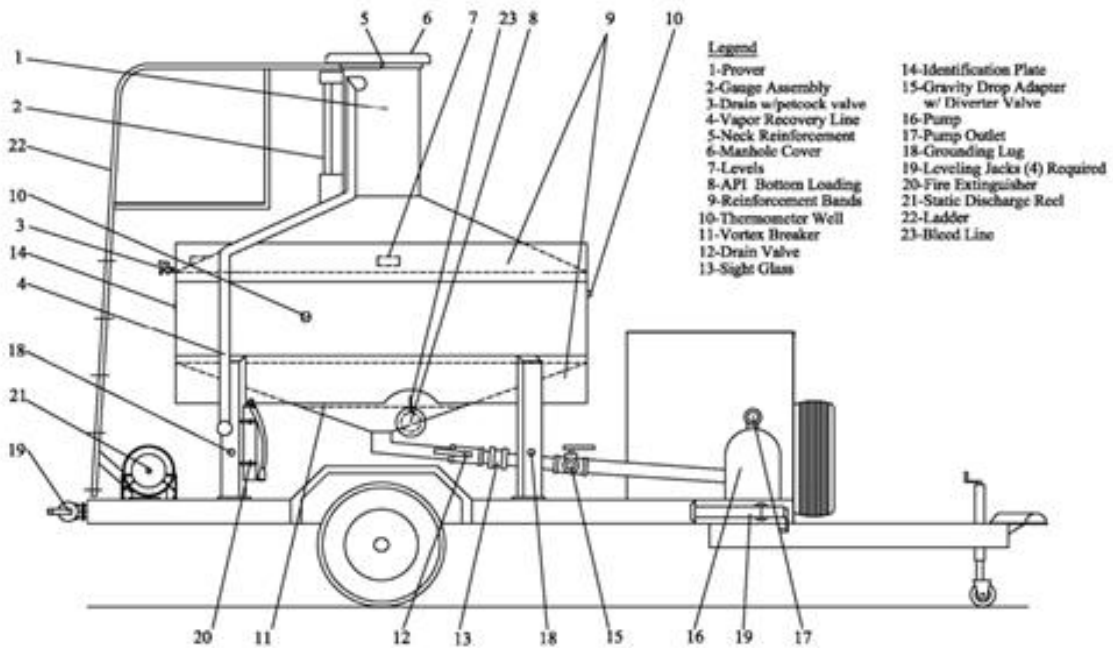

**LOT 2: 500L Measuring Can (Prover Tank)**

Specifications	Requested by BOBS
	1
Quantity	
Model	JY-CLC
Type	Tri-Foot with down outlet
Warranty	At least 2 years
Colour	Any
New	Yes
Material: Stainless Steel 304 with 2 x Thermometer Wells Complete with Trailer and all accessories as in the drawing shown below.	500L

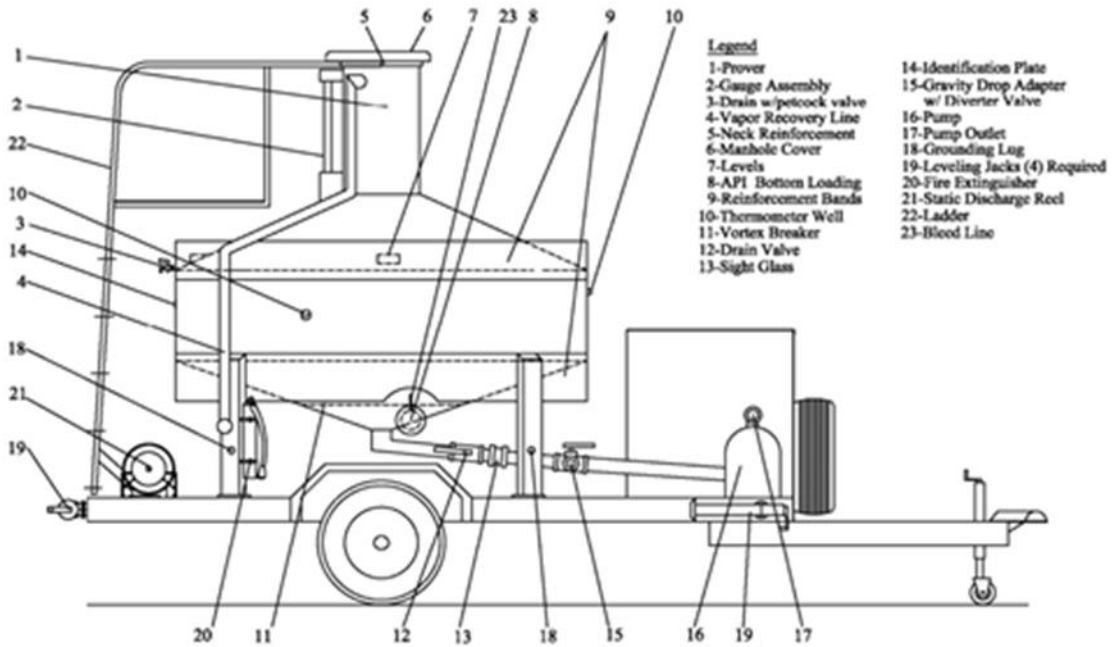

**LOT 3: Master Meter BM 950 + Wheel Trailer**

<b>Specifications</b>	<b>Requested by BOBS</b>
Quantity	1
Model	BM 950
Warranty	At least 2 years onsite
Colour	Any
New	Yes
Typical repeatability 0.02%. Maximum linearity 0.1% ( for example minus 0.05% to Plus 0.05%) over the flow rate range 130 to 1370 Litres Per minute. Inlet and outlet flanged 3 inch ASA150 Pressure 21 Bar. The meter has a Ductile iron manifold, Ni-Resist cast iron body, carbon vanes, Aluminium Rotor, Aluminium outer covers, Ni-resist cast iron inner Covers and high nitrile seals. The meter is fitted with a Mechanical calibrating mechanism, a mechanical Counter head with resetable register and non resetable Totalizer, and a direct coupled, mechanical rate of flow Indicator. Calibration in Litres. The meter will Additionally be fitted with a Vernier unit drum and will be tested and certified to a 6 point Master Meter Standard which meets all requirements for a single fuel Grade. It must be supplied complete with full Master Meter certification.	BM 950 + Wheel Trailer

**ANNEX 2. QUOTATION FORMAT**

<b>Lot No.</b>	<b>Description</b>	<b>Type, brand name equipment offered</b>	<b>Delivery period (in days from the signature of the PO)</b>	<b>Warranty period (in months)</b>	<b>Quantity</b>	<b>Unit Price (BWP) Vat inclusive</b>	<b>Total price (BWP) VAT inclusive</b>
1	200L Measuring Can (Prover Tank)				1		
2	500L Measuring Can (Prover Tank)				1		
3	Master Meter BM 950 + Wheel Trailer				1		

### **ANNEX 3. TECHNICAL COMPLIANCE FORMS**

Bidders shall complete these forms to confirm the compliance of the equipment offered to the Technical specifications. Failure to complete these forms will result in a rejection of the submission.

#### **LOT 1: 200L Measuring Can (Prover Tank)**

<b>Specifications</b>	<b>Supplied variations</b>
Quantity (1)	
Model	
Warranty (At least 2 years onsite)	
Colour (Any)	
New	
Material: Stainless Steel 304 with 2 x Thermometer Wells Complete with Trailer and all accessories as in the drawing shown below.	

#### **LOT 2: 500L Measuring Can (Prover Tank)**

<b>Specifications</b>	<b>Supplied variations</b>
Quantity (1)	
Model (JY-CLC)	
Type (Tri-Foot with down outlet)	
Warranty (At least 2 years)	
Colour (Any)	
New	
Material: Stainless Steel 304 with 2 x Thermometer Wells Complete with Trailer and all accessories as in the drawing shown below.	

**LOT 3: Master Meter BM 950 + Wheel Trailer**

Specifications	Supplied variations
Quantity (1)	
Model (BM 950)	
Warranty (At least 2 years onsite)	
Colour (Any)	
New	
<p>Typical repeatability 0.02%.            Maximum linearity 0.1% ( for example minus 0.05% to Plus 0.05%) over the flow rate range 130 to 1370 Litres Per minute. Inlet and outlet flanged 3 inch ASA150 Pressure 21 Bar. The meter has a Ductile iron manifold, Ni-Resist cast iron body, carbon vanes, Aluminium Rotor, Aluminium outer covers, Ni-resist cast iron inner Covers and high nitrile seals. The meter is fitted with a Mechanical calibrating mechanism, a mechanical Counter head with resetable register and non resetable Totalizer, and a direct coupled, mechanical rate of flow Indicator. Calibration in Litres. The meter will Additionally be fitted with a Vernier unit drum and will be tested and certified to a 6 point Master Meter Standard which meets all requirements for a single fuel Grade. It must be supplied complete with full Master Meter certification.</p>	

### **Other Requirements**

Supplier will install (including registration of software) and commission the proposed equipment.
All items will be on at least two-year warranty after commissioning of the equipment.
Bidders must indicate the brand that they are offering.
Please note that brochures are just an additional information. You are required to clearly provide appropriate specifications.
All prices quoted should be inclusive of taxes and duties applicable.
Supplier should not modify this form when completing the information.